

S-band Patch Antenna (SANT) Interface Control Document (ICD)



Document no.: ICD-20-00023

Revision: C

Date: 28 July 2015

	Name	Date	Signed
Author	Craig Olivier	28 July 2015	
Author			

Table of Contents

Table of Contents.....	1
1 Overview	2
2 Features.....	2
3 Detailed Characteristics.....	2
3.1 Typical Performance.....	3
3.2 Mechanical Specifications	4

1 Overview

The F'SATI S-band antenna (SANT) is a circularly polarised all metal patch antenna. The SANT conforms to the CubeSat standard and is thus primarily designed for CubeSat missions. The SANT is perfectly suited to transmit telemetry or payload data downlinks along with the F'SATI S-band Transmitter (STX).

2 Features

- Left or Right Hand Circular Polarization (Default Left)
- Covers the Amateur band in the S-band frequency range (2.4 to 2.45 GHz)
- Simple integration with structure
- Moderate Gain (8 dBi max)

3 Detailed Characteristics

The SANT has been optimised to be mounted in the centre of a 3U CubeSat as depicted in Figure 1. The measured performance results in this document are based on this configuration so deviations from this intended usage might result in less than optimum performance.

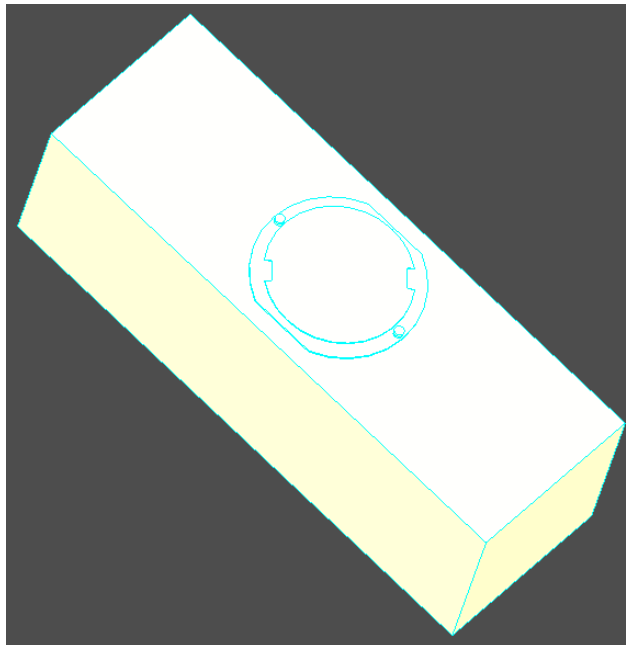

Figure 1: CAD model of SANT mounted in the centre of a 3U CubeSat

3.1 Typical Performance

The SANT is fully characterised within an anechoic chamber by subjecting it to comprehensive testing of various performance parameters. The particular parameters measured are Input Reflection Coefficient (S_{11}), polarization axial ratio, radiation patterns and gain. Below are some of the measured results.

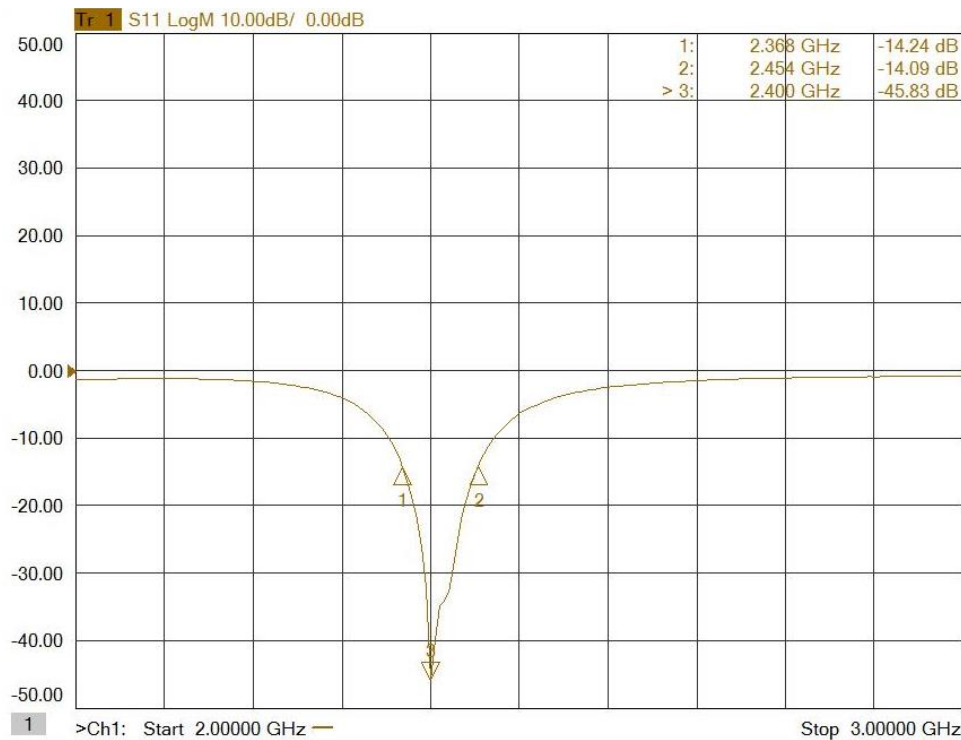

Figure 2: Input Reflection Coefficient (S_{11}) measurement

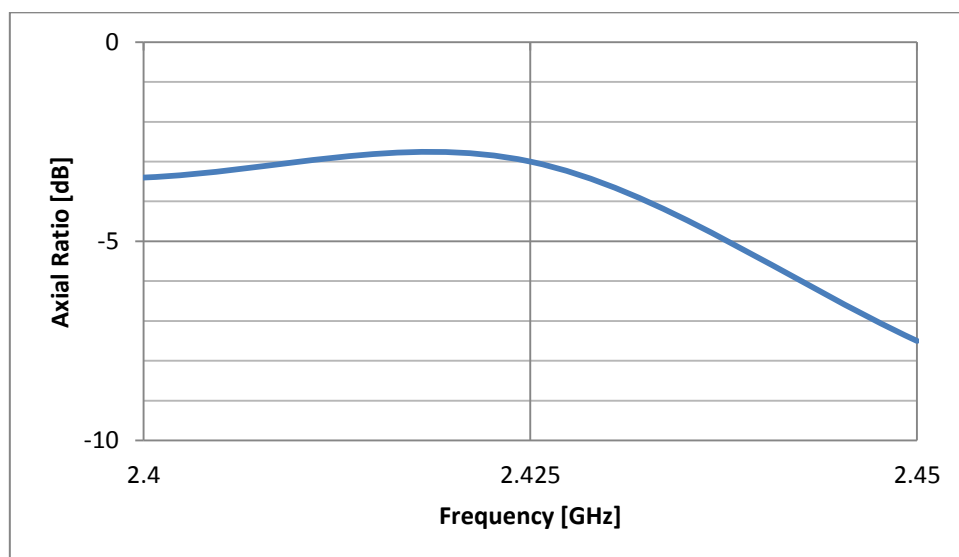

Figure 3: Axial Ratio measurement

3.2 Mechanical Specifications

3.2.1 Physical Specifications

- Mass < 50g (including connector)
- Dimensions (Figure 4)
 - 89 mm x 81.5 mm x 4.1 mm
 - Maximum height above the CubeSat chassis: 4.1 mm
 - The SMA connector intrudes into the chassis by 10 mm with the straight SMA (11 mm with right angled SMA)

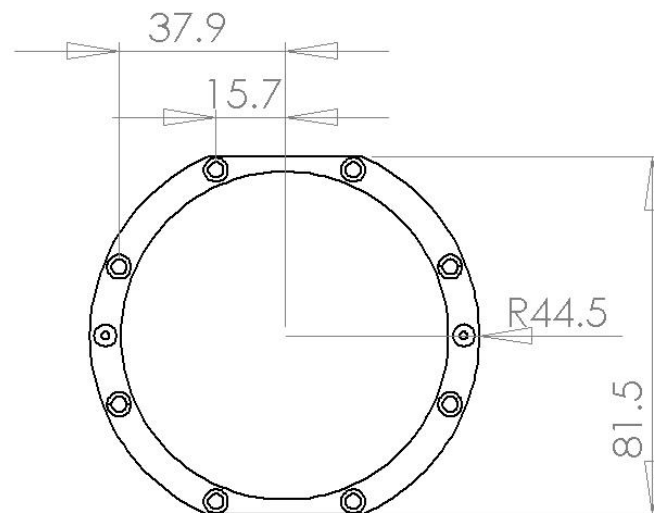

Figure 4: SANT Dimensions – Viewed from above

3.2.2 Interfaces

- Attachment – 8 x M2.5 counter sunk mounting screws
- RF connector – 50 ohm SMA female connector: Straight (default) or Right Angled (optional)

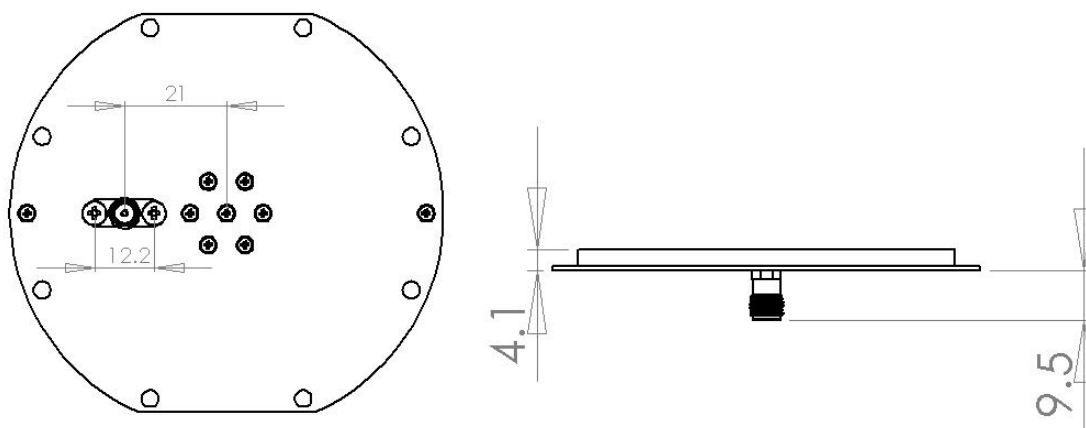

Figure 5: SANT Dimensions – Viewed from below and from the side with a straight SMA

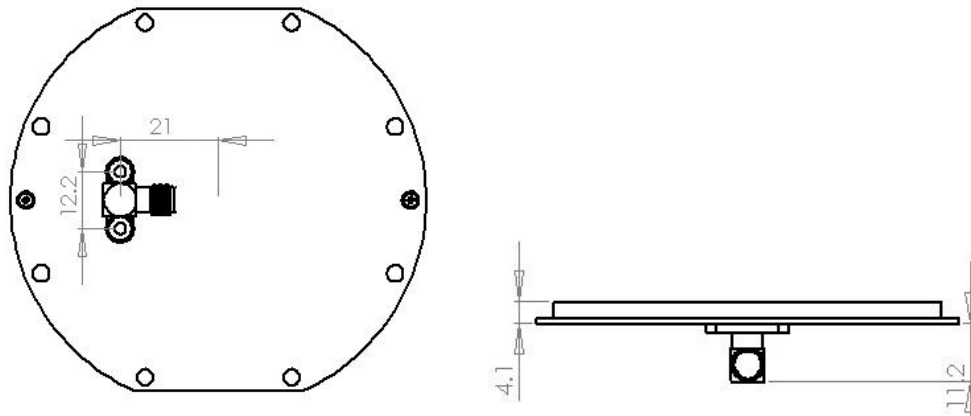

Figure 6: SANT Dimensions – Viewed from below and from the side with a right angled SMA